

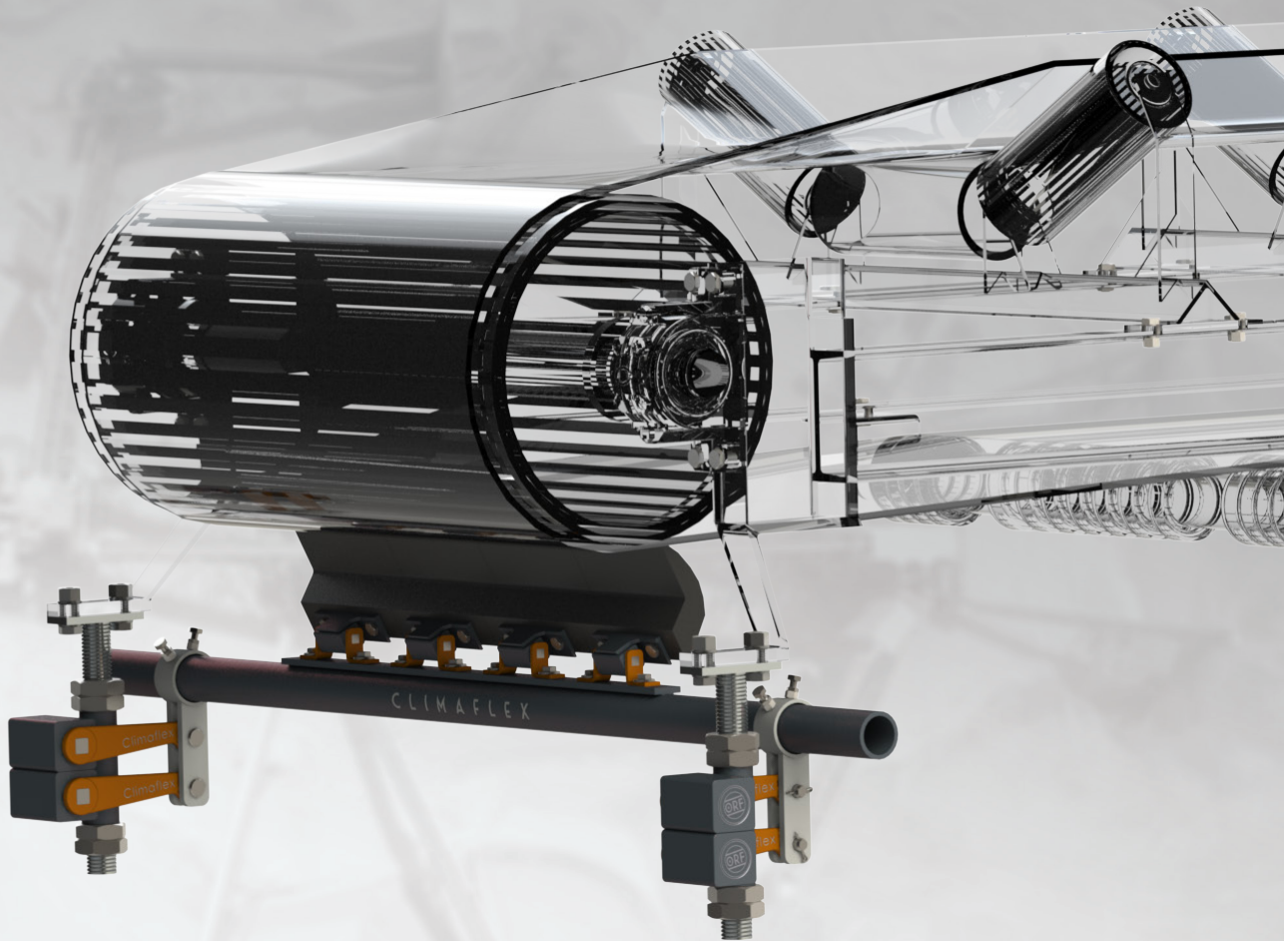

CLIMAFLEX®
BELT CLEANERS



MODULAR

POSITIVE

ATTENUATED



OCEAN RUBBER FACTORY LLC

CLIMAFLEX®

WES2 SECONDARY CLEANERS

CLEANING ELEMENT OPTIONS



♦ Alloy STEEL

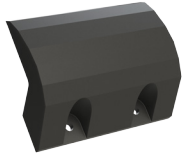

♦ ARMORED® Polymer Composite

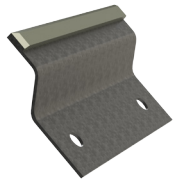

♦ TUNGSTEN Carbide

To the Conveyor Frame

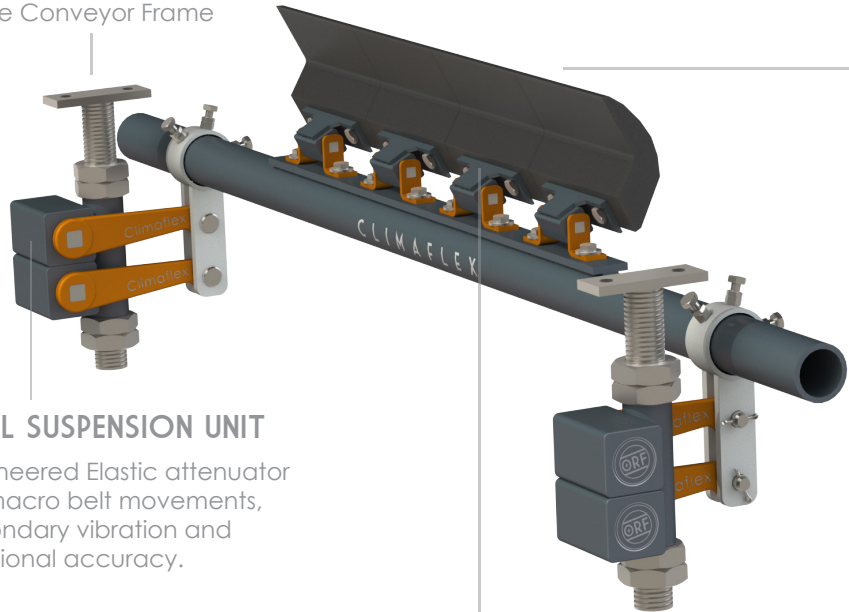

DUAL SUSPENSION UNIT

- ♦ Engineered Elastic attenuator for macro belt movements, secondary vibration and positional accuracy.

DEFLECTOR MODULE

- ♦ Obstruction Deflection
- ♦ Energized
- ♦ Primary Vibration Control
- ♦ Protects the Belt

CLEANING ELEMENTS

- ♦ MODULAR System allows for exchanging multiple types of cleaning elements.
- ♦ POSITIVE ANGLE cleaner.
- ♦ Segmented Elements for optimal wear management.

Simulation showing Energized Cleaning Element Movement

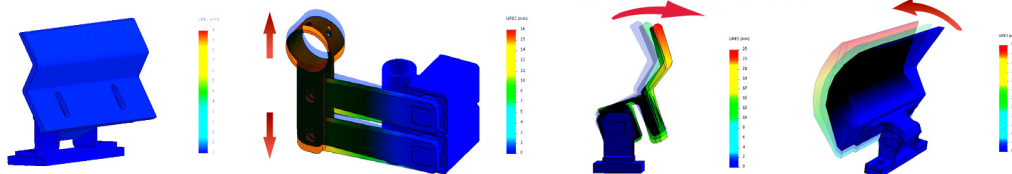



PU PRE-CLEANERS

- ◆ Climaflex® Primary Belt Scrapers remove carryback on the conveyor belt and keeps the belt as clean as possible.
- ◆ Simple & easy two-pin blade change.
- ◆ Fitted with various system engineered tensioners to provide optimal belt contact & cleaning efficiency.

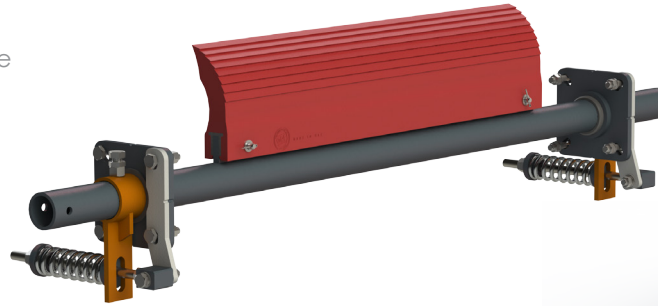

TENSIONER OPTIONS

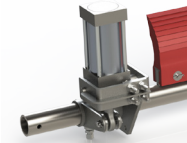

Pneumatic Tensioner

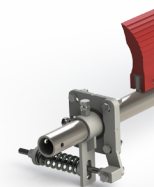

Spring Tensioner



Torsion-twist Tensioner

PU SECONDARY CLEANERS

- ◆ Soft contact on the belt.
- ◆ Excellent to wipe out watery carrybacks.
- ◆ Torsion mounted for extra protection.
- ◆ Easy Two-pin Blade Replacement.

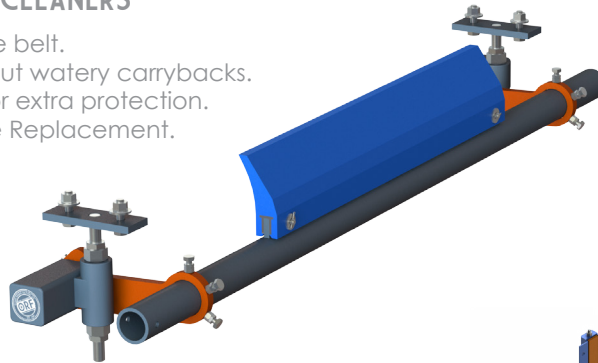

HELICAL BRUSH SECONDARY CLEANERS

- ◆ Self Cleaning-material will not load/settle due to open faced construction.
- ◆ Helical design ensures constant contact with the belt & a smooth noiseless brushing action.
- ◆ 1 HP & 2 HP motor powered options.
- ◆ Nylon & PP Bristle options are available.
- ◆ Excellent for Cleated (Chevron) belts.

PU BRUSH SECONDARY CLEANERS

- ◆ Seamless Moulded PU Brush Rings on a detachable drum mounted on a shaft.
- ◆ Effective cleaning action is ensured by the action of hundreds of flexible PU fingers.
- ◆ Excellent for Cleated (Chevron) belts.

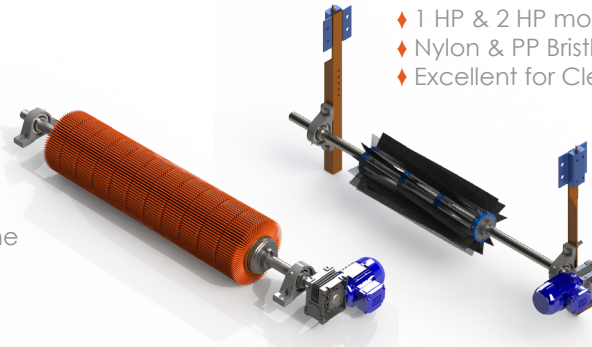

CLIMAFLEX®
BELT CLEANER OPTIONS



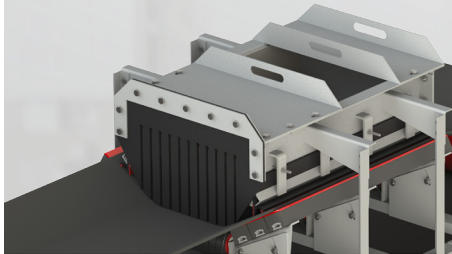

CLIMAFLEX® SKIRT SYSTEM

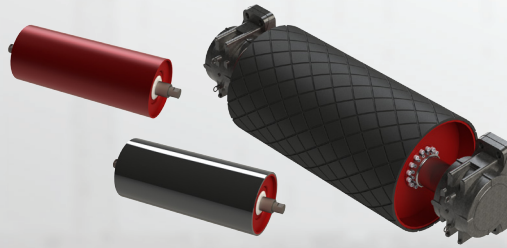

CLIMAFLEX® ROLLERS & DRUMS



CLIMAFLEX® TRACKER ROLLER

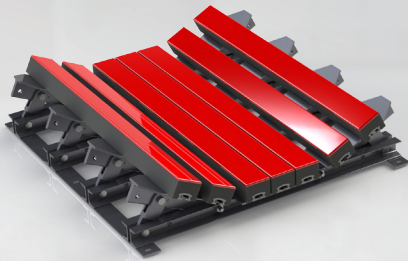

CLIMAFLEX® IMPACT CRADLE

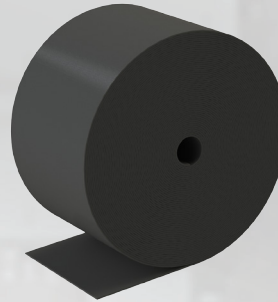

CLIMAFLEX® CONVEYOR BELT

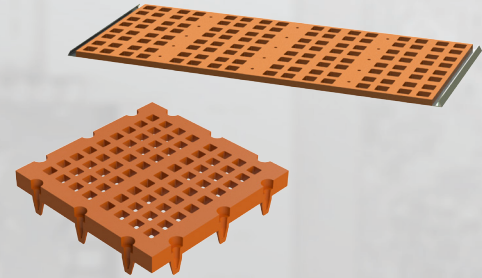

ARMORED® SCREENING SYSTEMS

**UNITED ARAB EMIRATES
OCEAN RUBBER FACTORY LLC - RAK**

Tel. +971 7 202 3888 / Fax: +971 7 258 4556
P.O. Box 6637, N.26-30, Al Ghail Industrial Park, Ras Al Khaimah



GENERAL ENQUIRIES: +971 6 5344 110

WWW.ORF.AE

INFO@ORF.AE